

**International Community Health
Department of General Practice and Community Medicine
Faculty of Medicine, University of Oslo, Norway**



**EVOLUTION OF HIV-1 IN NORTHERN TANZANIA:
A RETROSPECTIVE STUDY**

THESIS

By

Balthazar Melchior Rugaitika Nyombi

Thesis submitted as part of fulfillment of Master of Philosophy

Degree in International Community Health

Supervisor: Gunnar Bjune, Professor

Co-supervisors: Stig Jeansson, Professor

Holm-Hansen Carol, PhD

Barongo Longin, Mmed

Nkya Watoky, Professor

June 2002

Dedications

This work is dedicated to my father, the late Omulangira Melchior Rugaitika.

To my dear mother Ma Asteria, my beloved grand mother Omukaile Ma Yozefina, my brothers and sisters.

For your love and prayers.

TABLE OF CONTENTS

Dedications	2
Acknowledgements.....	4
Abstract.....	5
Abbreviations.....	6
Introduction.....	7
Global situation of HIV/AIDS	9
Current situation of HIV/AIDS in Tanzania.....	10
General description of a retrovirus	12
Replication cycle of HIV	13
Structure of HIV-1 genome	14
HIV-1 group M genetic variability	16
The global distribution of HIV-1 subtypes	17
Molecular epidemiology of HIV-1 in Tanzania.....	18
Subtyping techniques	19
Peptide-binding enzyme immunoassay.....	19
Polymerase chain reaction and DNA sequencing.....	20
Heteroduplex mobility assay.....	22
Peptide-binding enzyme immunoassay in HIV-1 subtyping	23
Rationale for using PEIA	25
Aim of the study.....	26
Research hypothesis.....	27
Main objective of the study.....	28
Specific objectives	28
Materials and methods	28
Study site.....	28
Study design.....	30
Peptides.....	30
Serum specimens	31
Serum sample selection.....	32
Serum sample controls.....	32
Sample analysis.....	32
V3 PEIA.....	33
V3 peptide antigen limiting dilution assay	34
gp41 PEIA.....	34
Results.....	35
Discussion and conclusion.....	40
Appendix.....	45
References.....	46

Acknowledgements

I praise God for His blessings and guidance throughout the period of this work.

I wish to thank the Section for International Health, Department of General Practice and Community Medicine at the University of Oslo for providing me with the opportunity to pursue the degree of Master of Philosophy in International Community Health. In addition, I am grateful to Statens Lånekasse for financial support. Special thanks are extended to the Ministry of Health and Kilimanjaro Christian Medical Centre (KCMC) in Tanzania for granting me permission to undertake the studies in Norway. I thank Prof. Gunnar Bjune, my supervisor for his academic guidance, critics and support. Special thanks are extended to the Section for International Health for financial support to cover expenses related to fieldwork and for making this work possible.

Appreciation and special thanks to my friend and co-supervisor Dr. Carol Holm-Hansen for tireless encouragement and making it possible for me to pursue further studies. I am also grateful for her professional guidance, support and enthusiasm.

Appreciation is also extended to Prof. Stig Jeansson my co-supervisor for continual assistance, dedication, guidance, helpful critics and material support for this work. Prof. Stig and Dr. Carol, without you this thesis would not have become a reality.

Furthermore, I would like to thank Dr. Pontiano Kaleebu of UVRI, Entebbe, Uganda for the invitation and training in peptide ELISA at his institute. Thank you for the guidance and advice. I wish to acknowledge the Centralized Facility for AIDS Reagents, supported by the EU Programme EVA (contract BMH4 97/2515) and the UK Medical Research Council for peptide donation. I also thank Dr. Chou Pau of CDC, Atlanta for donating the gp41 peptides. Without their donations this work would not have been possible.

I would like to thank KCMC and the Research Laboratory for allowing me to use the banked sera and laboratory facilities for analysis. Appreciation is extended to Prof. Nkya and Dr. Barongo, my co-supervisors, for their encouragement and advice during the sample analysis.

To my dearest wife Evelyn, and children Lacatus, Henrick and Vanessa. I thank them for their patience, understanding and prayers.

To my fellow classmates, thank you for being my jovial family in Oslo.

Abstract

Development of an effective vaccine against HIV has faced great challenges due to the great genetic diversity of the virus. However, in different geographical areas candidate vaccines based on the prevalent HIV-1 subtype(s) are now entering clinical trials. Genotypic and serological assays have been used in HIV-1 subtyping. The peptide-binding enzyme immunoassay has been a useful tool for subtyping HIV-1. This assay in combination with an antigen limiting dilution assay was established at the Kilimanjaro Christian Medical Centre (KCMC) in Moshi, Tanzania. HIV-1 positive serum samples stored at KCMC were characterized using these assays to determine the trend since the start of the epidemic. In addition, the distribution of HIV-1 subtypes currently circulating in northern Tanzania was determined in order to provide important information that might be of relevance to future vaccine studies and trials in Tanzania.

Frozen HIV-1 positive serum samples from individuals diagnosed at KCMC between 1985 and 2001 were used in this study. Synthetic peptides representing HIV-1 subtypes A, B, C, D and E derived from consensus gp120 V3 sequences were used in an indirect peptide-binding enzyme immunoassay and an antigen limiting dilution assay. The gp41 peptide D was used to increase the specificity by discriminating subtype D from non-D viruses.

Two hundred and twenty six samples were analyzed; 196 (87%) samples were successfully subtyped while 30 (13%) could not be typed using these methods. In 1985 the prevalent subtypes were A (52%) and D (48%). Subtype C started to circulate in the late 1980s and in 2001 was the most prevalent circulating subtype in Tanzania. The currently circulating subtypes are A (32%), C (51%) and D (17%).

HIV-1 vaccines entering clinical trials in Tanzania should be based on the predominant circulating subtype(s).

Abbreviations

AIDS	acquired immunodeficiency syndrome
CRF	circulating recombinant forms
CCR5	CC chemokine receptor-5
CD4	cluster of differentiation 4
CD8	cluster of differentiation 8
CXCR4	CXC chemokine receptor-4
DNA	deoxyribonucleic acid
ELISA	enzyme linked immunosorbent assay
<i>env</i>	envelope
<i>gag</i>	group associated genes
<i>gp</i>	glycoprotein
HIV-1, -2	human immunodeficiency virus type 1, -2
HMA	heteroduplex mobility assay
HTA	heteroduplex tracking assay
IDR	immunodominant region
KCMC	Kilimanjaro Christian Medical Centre
LTR	long terminal repeat
MHC	major histocompatibility complex
MOH	Ministry of Health
NACP	National AIDS Control Programme
<i>nef</i>	negative factor
NSI	non-syncytium inducing
PCR	polymerase chain reaction
PEIA	peptide enzyme immunoassay
<i>pol</i>	polymerases
<i>rev</i>	retroviral regulatory protein
RNA	ribonucleic acid
mRNA	messenger RNA
SD	standard deviation
SSA	sub-Saharan Africa
SI	syncytium inducing
<i>tat</i>	transcriptional transactivator
UNAIDS	Joint United Nations Programme on HIV/AIDS
<i>vif</i>	viral infectivity factor
<i>vpu</i>	viral protein U
Wb	Western blot
WHO	World Health Organization

Introduction

The human immunodeficiency virus (HIV) has brought about a global epidemic far more extensive than what was predicted even a decade ago. Since the epidemic began, HIV has now infected more than 60 million individuals. By the end of 2001, an estimated 40 million people were living with HIV worldwide (1). HIV is the etiology of the slow progressing and serious acquired immunodeficiency syndrome (AIDS). There are two HIV types, HIV-1 and HIV-2, of which the first one is responsible for the pandemic. HIV-1 infections are characterized by a brief acute phase with high viraemia followed by a chronic phase characterized by the depletion of CD4⁺ T-lymphocytes in the peripheral circulation to less than 20% of normal within 8 – 10 years. Opportunistic infections and certain rare cancers occur due to the immunosuppression. AIDS is the leading cause of death in Sub-Saharan African (SSA) and the fourth biggest killer worldwide. The epidemic has a profound impact on social, political, cultural and economic development. Millions of people in SSA carry the virus but do not know they are infected. Many more know little or nothing about how to protect themselves against HIV. Developing countries in SSA cannot care for their HIV infected people and preventive efforts are very difficult. In light of the current HIV/AIDS situation it is clear that preventive methods that are inexpensive, accessible and effective are urgently needed. Hence, a HIV vaccine may be one of the best preventive methods for most of the developing countries such as Tanzania. The heterogeneity of HIV found in different parts of the world indicates that the strains initially used to develop vaccine candidates were not representative of the global epidemic. The genetic variability of HIV is considered to be one of the major obstacles in the design and development of effective HIV vaccines.

Kaleebu and colleagues in Uganda developed an algorithmic method to subtype HIV-1 using a peptide-binding enzyme immunoassay (PEIA), the heteroduplex mobility assay (HMA) and DNA sequencing. Serological analysis using a V3 peptide antigen limiting dilution assay and a gp41 PEIA correctly identified 78% of characterized HIV-1 samples (2). We decided to use the serological method of Kaleebu in the present study.

Our study provides information on currently circulating HIV-1 subtypes as well as of subtypes that occurred from 1985 to 2001 in northern Tanzania. This information is of value in the development of a HIV vaccine for Tanzania. The efficacy of vaccine candidates may be strain or subtype specific. It is therefore important to know the distribution of the HIV-1 subtypes in order to evaluate the effectiveness of the proposed vaccine candidates and to target future vaccine development and laboratory testing. The public health implications of such findings include prevention and diagnostic strategies.

Until now the information available on the molecular epidemiology of HIV-1 in Tanzania is based on limited data generated from small hospital-based descriptive studies done ten years after the first case of HIV was reported (Table 1). The present study indicates that HIV-1 subtypes A and D were the first in northern Tanzania. Furthermore, it is shown that subtype C was introduced in northern Tanzania in late 80s and now is the most prevalent HIV-1 subtype circulating in the region. The present study demonstrates that subtypes A, C and D are the currently circulating HIV-1 subtypes in northern Tanzania. It is important that vaccine candidates in Tanzania should be based on these HIV-1 subtypes.

The purpose of this study was to establish the PEIA and use it to track the evolution and distribution of HIV-1 subtypes in northern Tanzania for the period from 1985 to 2001.

Global situation of HIV/AIDS

HIV was first recognized in 1981 among homosexual men in USA. These men had infections seldom observed among immunocompetent individuals. Later it was discovered that these individuals had a severe immunodeficiency. HIV infection was not only confined to homosexual men, new cases in women were reported and heterosexual HIV transmission was described (3). It was noted that exchange of body fluids from an infected individual to an uninfected individual was the mode of transmission. This was reported for heterosexual transmission (3) as well as for intravenous drug users (4), prenatal infections and breastfeeding (5), transfusions, organ transplants and inseminations (6). Globally, the leading mode of transmission is heterosexual. The challenge caused by HIV varies geographically depending on how far and fast the virus is spreading. According to the UNAIDS and WHO estimates for the year 2001, the number of people living with HIV/AIDS is 40 million and about 5 million people were newly infected with 14,000 new infections everyday. About 85% of the new infections were in adults (15-49 years old) and 50% of these were among women. As a result we are witnessing a rise in the number of children born with HIV. The total number of deaths due to AIDS in the year 2001 was estimated to be 3 million worldwide (1).

Countries in SSA are experiencing a severe impact of the HIV epidemic. Regional HIV/AIDS statistics by the end of 2001 show that the total number of people living with HIV/AIDS is estimated to be 28 million which is 70% of total world's people living with HIV/AIDS. The total number of people newly infected with HIV during 2001 in SSA was estimated to be 3.4 million, which is 68% of the world's newly infected people in the

same year (1). Eastern Europe and central Asian countries have also shown a rapid increase of the HIV epidemic. UNAIDS and WHO estimates put the number of adults and children living with HIV/AIDS in these countries at 1 million by the end of the year 2001 as compared to 700,000 in the previous year.

The HIV epidemic in some SSA countries seems to be stabilizing. This may be due to the fact that epidemic has been going on for so long. The infection has already affected many people in the sexually active population leaving a smaller pool of people still able to acquire the infection. The other factor is the success of preventive programs in some of the African countries, notably Uganda, which has reduced national infection rates. The epidemic in Uganda has not only stabilized but, more importantly, both the prevalence and incidence rates are decreasing.

Current situation of HIV/AIDS in Tanzania

The first AIDS case was reported in the Kagera region in northwestern Tanzania in 1983 (7). This started as a disease of businessmen and women who were crossing the Tanzania/Uganda border. They often wore shirts with a picture of an eagle by the name of “Juliana”. Hence, the sick persons were said to have acquired “Juliana” disease.

Three cases were reported in 1983 and by the end of 1985 eight of the twenty regions of Tanzania had reported 404 AIDS cases to the Ministry of Health (MOH). By the end of 1986 the number reached 1,525 and all the regions in the country had reported AIDS cases (8, 9). In 1988 the Ministry of Health established the National AIDS Control Programme (NACP) to coordinate the AIDS control activities and monitor the HIV/AIDS

epidemic in Tanzania. Ten years after the first case was reported (8, 9) the total number of notified cases had reached 73,572. The cumulative number of AIDS cases reported to the NACP from 20 regions of the Tanzanian mainland by the end of 2000 was 130,386 with 11,673 newly reported cases (9). However, according to the UNAIDS and WHO estimates, Tanzania had 1.3 million people living with HIV/AIDS by the end of 1999. The AIDS deaths during 1999 were estimated to be 140,000. The estimated cumulative number of orphans since the beginning of the epidemic was 1.1 million with two thirds of these orphans still living (10).

In the 2000 report by the NACP, the overall prevalence among blood donors was 9.9% countrywide. Furthermore, reports from voluntary counseling and HIV testing centers showed that 6,539 clients were counseled, 3,338 agreed to be tested and out of them 59.5% tested HIV positive. Heterosexual HIV transmission accounts for 77.2%, mother to child 3.4% and blood transfusion 0.4% of all HIV transmissions in Tanzania. Information on the mode of transmission for 19% was not available. Data derived from 28 sentinel surveillance sites show that the countrywide HIV prevalence among pregnant women for the year 2000 ranged from 4.2% in one site in Mwanza region to 32.1% in one site in Iringa region (9). It is clear that the number of HIV/AIDS cases in Tanzania is on the rise resulting in early mortality, loss of manpower and breadwinners, increase in the number of orphans and social instability. Tanzania being a developing country cannot care for her HIV infected patients and it is very difficult to establish effective preventive measures.

It is clear that preventive methods that are inexpensive, accessible and effective are urgently needed in response to the current HIV/AIDS situation. Hence, an HIV vaccine

may be one of the best preventive methods for most developing countries including Tanzania.

General description of a retrovirus

HIV is a RNA virus that belongs to the family of retroviruses, genus *Lentiviridae* (11). The central nucleocapsid core of the virion contains two copies of the RNA genome, the enzymes reverse transcriptase and integrase, and core proteins. Surrounding the core is protein capsid surrounded by a phospholipid envelope with embedded surface glycoproteins (figure 1).

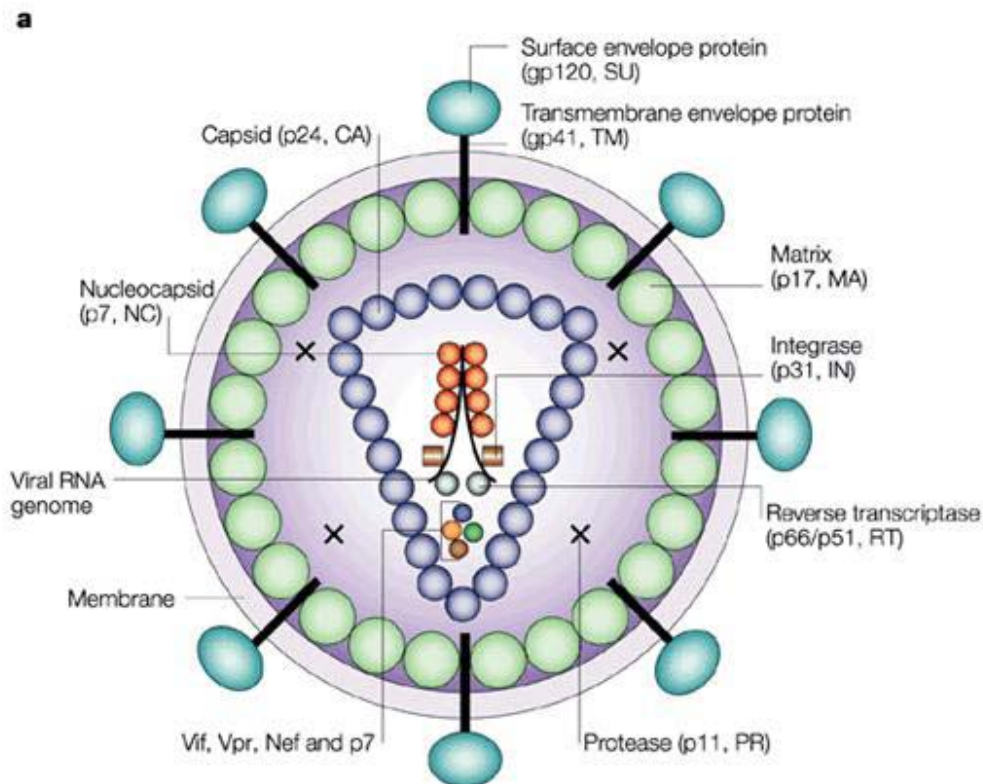

Figure 1. Model of HIV-1 virion.

Source: <http://www.nature.com/reviews/immunol> - April 2002 volume 2.

Replication cycle of HIV

HIV replicates within a host cell using RNA as a template to make DNA. HIV infection begins when the HIV particle encounters a cell with the surface receptor molecule CD4. The virus particle uses gp120 to attach itself on the cell membrane and enters the CD4 positive cell with the help of the chemokine receptors CXCR4 or CCR5 (12). CXCR4 is a co-receptor for the T-cell tropic syncytium inducing (SI) HIV strains while the CCR5 is strictly for macrophage tropic non-syncytium inducing (NSI) HIV strains. Recently, it

has been shown that some HIV-1 variants can infect CD8 cells rather than CD4 cells. (13) (14).

Within the cell, the virus particle releases its two RNA molecules and the enzyme reverse transcriptase converts the viral RNA into DNA. This HIV DNA then moves into the cell nucleus where, with the help of the enzyme integrase, it is inserted into the host cell DNA. Once in the cell's chromosomes, HIV DNA is called proviral DNA. The viral mRNA is transcribed from the HIV proviral DNA by the host cell RNA polymerase and translated into several large polyproteins. Copies of RNA and newly created polyproteins move closer to the cell membrane. New virions begin to form and bulge on the side of the of the host cell. Then the virions separate completely from host cell in the budding stage. During the budding from the host cell membrane, the viral proteinases become active resulting in cleavage of various subunits and generation of the mature form of HIV (15) (12).

Structure of HIV-1 genome

The HIV genome consists of two identical molecules of single stranded, positive polarity RNA. Each RNA strand is approximately 9200 bases long. Like all retroviruses, the HIV genome (figure 2) consists of structural genes *gag*, *pol* and *env*, which are in the order 5'-*gag-pol-env-3'* and encode the structural proteins. In addition the HIV genome has six regulatory genes including *tat* and *rev* for the replication of the virus and *nef*, *vif*, *vpr* and *vpu*, which are accessory genes, not involved in replication. The *gag* gene encodes the internal core proteins p7, p17 and p24. The *pol* gene encodes reverse transcriptase, which transcribes RNA genome into DNA, protease that cleaves precursor polypeptides and

integrase that integrates viral DNA into host cell DNA. The *env* gene encodes gp160, the precursor of the two glycoproteins gp120 and gp41. The regulatory genes required for the replication, *tat* (transactivating protein) that activate the transcription of the viral genes, and *rev* (regulator of expression of virion protein) that controls the transcription of mRNA from the nucleus to the cytoplasm.

The accessory genes include *nef* (negative regulatory factor) that decreases expression of CD4 proteins and MHC class 1 proteins on the surface of infected cells, and *vif* (viral infectivity factor) that stabilizes newly synthesized viral DNA. Other genes are *vpr* that transport viral core from the cytoplasm into the nucleus in non-dividing cells and *vpu* (viral protein U) that enhances virion release from the cell.

At both ends of the genome are the long terminal repeats (LTR) that are transcription initiation sites (12)

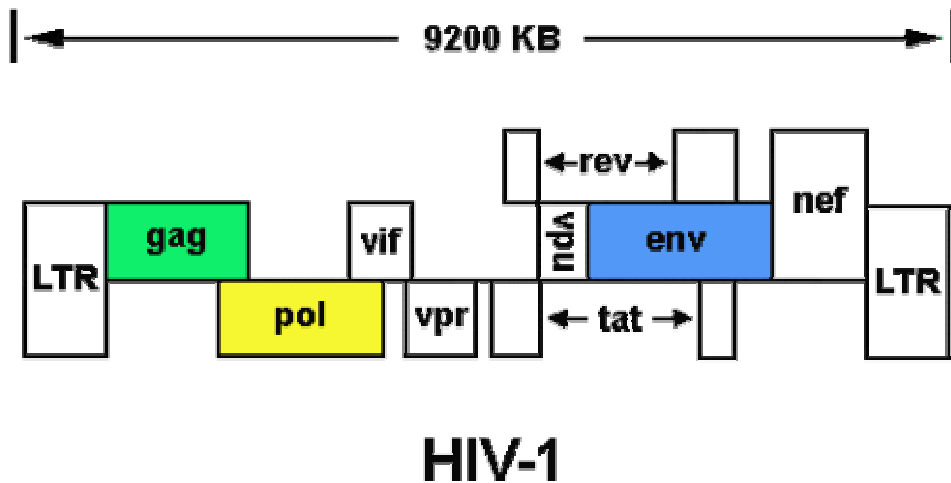

Fig. 2 HIV-1 genome.

Source: <http://www-medlib.med.utah.edu/WebPath/TUTORIAL/AIDS/AIDS008.html>.

HIV-1 group M genetic variability

HIV has two main mechanisms of establishing genetic variation: mutation that includes point mutation, deletion, insertion and duplication, as well as recombination. The genetic variability is primarily due to the high error rate of the viral reverse transcriptase that results in approximately 10 genetic base changes per replication cycle. This is due to lack of 3'-5' exonuclease activity for proofreading (16) (17). The envelope gene seems to be subject to the most extensive genetic variation although alterations also occur in other genes. HIV undergoes continuous genetic change within the individual patient, who usually harbors a swarm of highly related but individually distinguishable viral variants referred to as quasispecies (18). The genes that encode gp120 mutate rapidly particularly in the V3 loop, the most immunogenic region of gp120. Based on the differences in the sequence of the genes that encode gp120, HIV-1 has been subdivided into subtypes A, B, C, D, E, F, G, H, I, J and K (19) (20) (21). With the growth of the full HIV-1 genome sequence database of HIV-1 subtypes have been reclassified into A, B, C, D, F, G, H, J, K and several circulating recombinant forms (CRF). Subtypes E and I have been reclassified as CRF01_AE and CRF03_cpx, respectively (22). The mutations that lead to the substitution of the positively charged amino acids at specific positions in the V3 loop correlate with the syncytium inducing property of the virus (23) (24).

Recently, it has been shown that recombination between different HIV-1 subtypes can take place *in vivo* (25). This indicates the existence of co-infection or super-infection with different genetic variants. Despite the genetic variation between different subtypes, the genetic determinants of biologically important domains are largely conserved among the known subtypes (23).

The global distribution of HIV-1 subtypes

HIV-1 subtypes are unevenly distributed in different geographical locations. Almost all subtypes are present in SSA where the HIV-1 epidemic is believed to be of long duration. Subtypes A, B, C, D, F, G, H, CRF01_AE and group O are found in west and central Africa. Subtype C is prevalent in the horn of Africa including Ethiopia, in addition to the south and southwest of Africa.

In Asia subtypes B, C and CRF01_AE are predominant, subtype C is predominant in India while CRF01_AE predominates in Thailand.

In North America subtype B is predominant in addition to the identification of subtypes C, D, CRF01-AE, CRF02-AG and group O. Subtypes that are found in south America include B, F, C and CRF12-BF. In Europe subtype B accounts for the majority of HIV-1 infections with non-B subtypes being detected in several parts of the continent. Group O has been reported in France and Spain. Subtype F has been reported in Romania and subtype G in Russia. HIV-1 infections in Australia have been reported to be of subtype B. However, due to the increased extent of travel and mobility of people from one region to another, HIV subtypes are no longer limited to a few geographical areas but can be found throughout the majority of countries (19) (20) (21) (22).

Molecular epidemiology of HIV-1 in Tanzania

Studies conducted in Tanzania on the molecular epidemiology of HIV-1 subtypes showed a predominant occurrence of subtype A, C and D. Subtype C is predominant in Mbeya in the southwestern part of Tanzania bordering Zambia as well as with other southern African countries. Hoelscher and colleagues (26) studied HIV-1 V3 serotypes of patients in Mbeya town and four subtypes were identified: A (29%), C (55%), D (15%) and G (1%). Subtypes A and D have been documented in Dar-es-Salaam and Kilimanjaro. A study on 14 virus isolates by Holm-Hansen and colleagues (27) in Dar-es-Salaam indicated divergent and clustered sequences of HIV-1 subtypes A, C and D. A study by Blackard and colleagues (25) on the diversity of HIV-1 LTR following mother-to-child transmission in 19 mother-infant pairs, detected subtypes A, C, D and intersubtype recombinants. In a recent study by Kiwelu and colleagues (28) in Kilimanjaro, northern Tanzania, on the determination of nucleotide sequences of the gp120 V3 from isolates circulating in the region, subtypes A, C, D and B-like sequences were identified (28).

In summary, the available information on the molecular epidemiology of HIV-1 in Tanzania is based on limited data generated from a small number of hospital-based studies. All these studies were done ten years after the first HIV/AIDS case was reported in Tanzania. Table 1 summarizes the previous studies done on the molecular epidemiology of HIV-1 in Tanzania.

Table 1. Summary of previous studies on molecular epidemiology of HIV-1 in Tanzania.

Author	Year of study and place	Year of publication	HIV-1 subtypes identified
Hoelscher M. et al. (26)	? - Mbeya	1998	A, C, D and G
Renjifo B. et al. (29-31)	1997 – DSM*	1999	A, C, D and CRF
Lyamuya E. et al. (32)	1997- DSM	2000	A, C and D
Hoelscher M. et al. (33)	1997 - Mbeya	2001	A, C and CRF (A/C, C/D)
Blackard JT et al. (25)	1997 - DSM*	2001	A, C, D and CRF
Kiwelu IE et al. (28)	1998 – K'njaro	2000	A, B, C and D
Holm-Hansen et al. (27)	1994 - DSM	2000	A, C and D

* *Samples were from the same study.*
 DSM – *Dar-es-Salaam,*
 K'njaro – *Kilimanjaro*

Subtyping techniques

Peptide-binding enzyme immunoassay

The peptide-binding enzyme immunoassay (PEIA) provides HIV-1 classification based on antibody detection or serotyping. The antibodies bind to subtype-specific, immunodominant synthetic peptides encoded by HIV-1. Serotyping HIV-1 has been successfully used in several studies in Thailand (34) where subtypes E and B are predominant and in Uganda (2) where subtypes A and D are predominant. In areas where subtypes A, C and D are predominant serotyping has been difficult due to a high degree of cross-reactivity. Subtype A cross-reacts with C and, to a lesser extent, subtype B with D. The development of the antigen limiting dilution assay that detects high avidity

antibodies improved the specificity of the V3 PEIA (35). The antigen limiting dilution assay is characterized by subjecting a single dilution of the serum sample to increasing dilutions of antigen. A 17-amino acid immunodominant region (IDR) of the envelope gp41 from ELI, an HIV-1 isolate from Zaire discriminates subtype D from non-D viruses (2). PEIA requires less rigorous sample processing, is practical for large scale screening of samples in the field environment, is easy to perform and requires less sophisticated equipment compared to molecular techniques. PEIA is therefore a useful tool in molecular epidemiological studies.

Polymerase chain reaction and DNA sequencing

The polymerase chain reaction (PCR) method is based on a primer-initiated bi-directional DNA synthesis of a region of nucleic acid. This method is the basis of genotypic analysis and enables the detection of limited copy numbers of DNA. DNA can be either synthesized from plasma RNA or proviral DNA extracted from the mononuclear cells. PCR on RNA templates (reverse transcriptase PCR or RT-PCR) is preceded by a reverse transcription step to produce cDNA. On several cycles DNA strands can be amplified exponentially on subjection to specific primers and polymerase enzyme (figure 3). Sets of HIV-1 subtype specific primers have been used in PCRs to differentiate distinct genotypes (36).

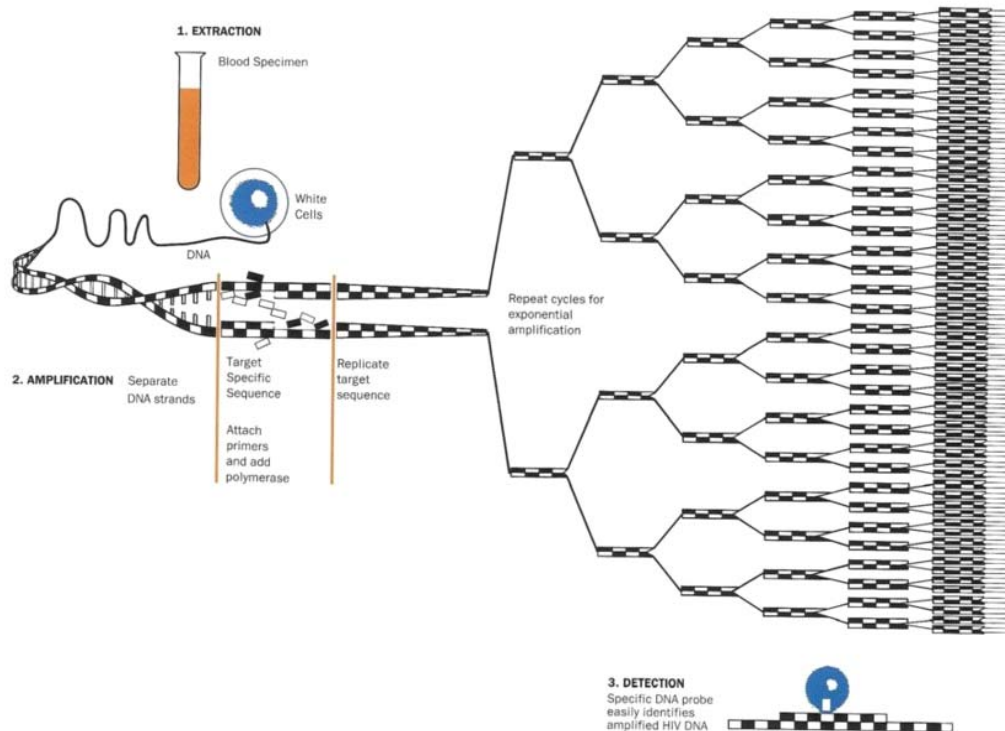
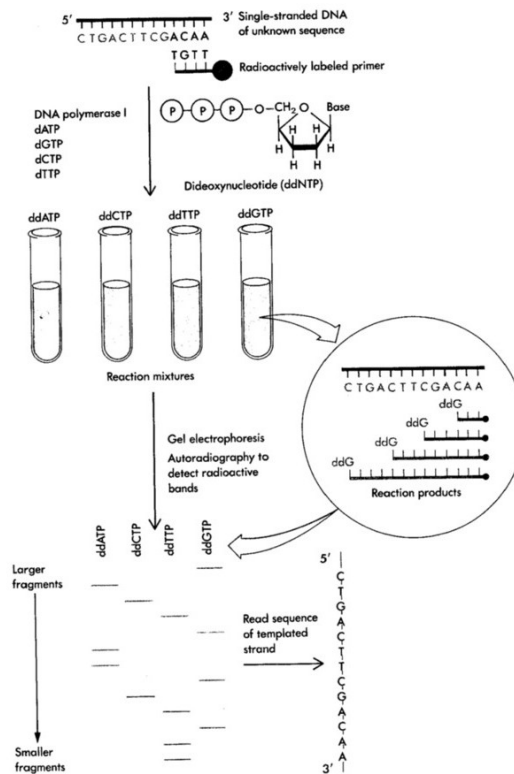

Fig. 3 Polymerase chain reaction

PCR amplicates may be further subjected to DNA sequencing in order to elucidate the nucleic acid pattern, or sequence, in a specific region of the HIV genome. DNA sequencing is considered to be the “gold standard” for HIV genotyping. The DNA sequencing method mostly commonly used, known as dideoxy chain termination, was developed by Sanger. In this method a dideoxynucleotide is incorporated into a growing DNA strand, subsequently stopping chain growth, preventing the formation of a phosphodiester bond with next the next incoming nucleotide. Four different reactions are run, each with a different dideoxynucleotide. The products of each reaction are a series of incomplete elongated segments, which are separated by gel electrophoresis (figure 4). The DNA sequences can be read from the bands produced in the gel. Generated sequences can be compared to sequences deposited in the database to determine subtype.



DNA sequencing

Fig. 4 DNA sequencing.

Source: Watson J, Hopkins NH, Roberts JW, Steitz JA, Weiner AM. Molecular Virology of the Gene, The Benjamin/Cummings Publishing Company, Inc., Menlo Park, CA, 1987. Figure 9-45.

Heteroduplex mobility assay

Delwart developed the heteroduplex mobility assay (HMA) to evaluate viral heterogeneity and for genetic typing of HIV-1(18). Heteroduplexes are formed when two non-identical but closely related single-stranded DNA fragments anneal. They form structurally distorted DNA molecules at mismatched base pairs and at unpaired bases, where an insertion or a deletion in the nucleotide sequence has occurred. These structural distortions cause the heteroduplex to migrate more slowly than the homoduplex during acrylamide gel electrophoresis and thus can be differentiated (figure 5).

HMA is highly specific, rapid and inexpensive compared to DNA sequencing.

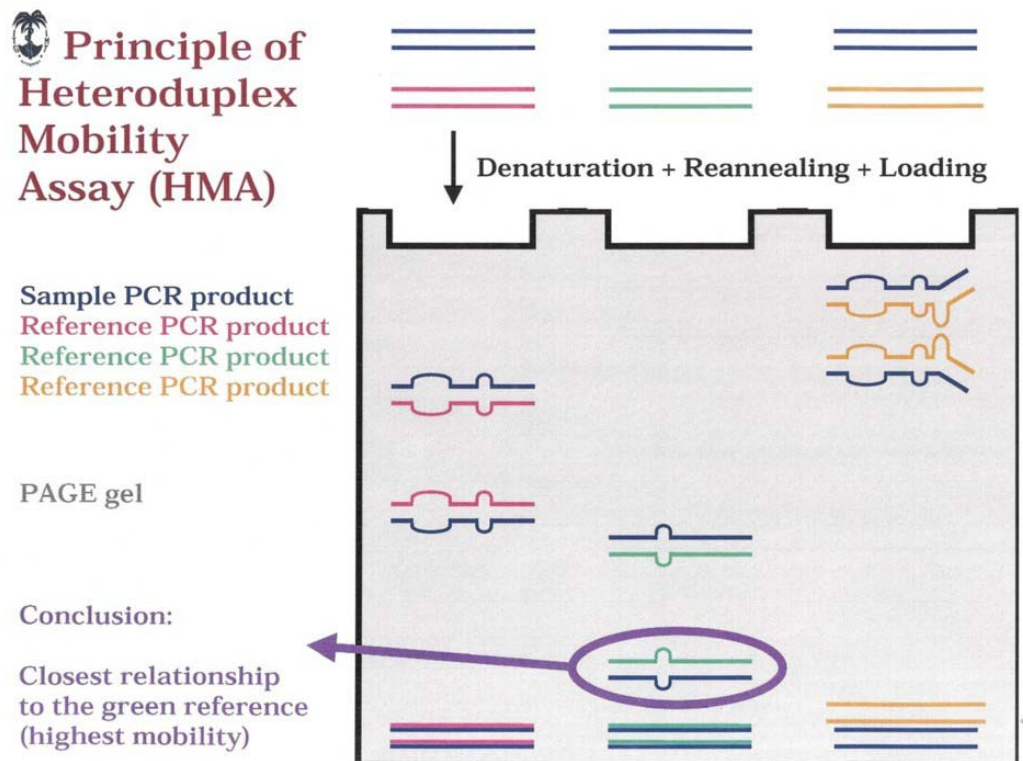

Fig. 5 Heteroduplex mobility assay

Peptide-binding enzyme immunoassay in HIV-1 subtyping

Molecular epidemiological studies for HIV-1 have been greatly facilitated by the development of algorithmic methods using PEIA followed by the HMA and finally DNA sequencing for the difficult samples. (2). The peptide-binding enzyme immunoassay enables the detection of subtype-specific antibodies using an enzyme substrate reaction. Standard enzyme linked immunosorbant assay plates are coated with specific peptides representing different HIV-1 subtypes. Subtype-specific antibodies in the serum samples will bind to the respective peptides. An anti-human immunoglobulin enzyme conjugate is

added followed by the appropriate substrate. The result of the reaction is a coloured product that can be measured spectrophotometrically (figure 6).

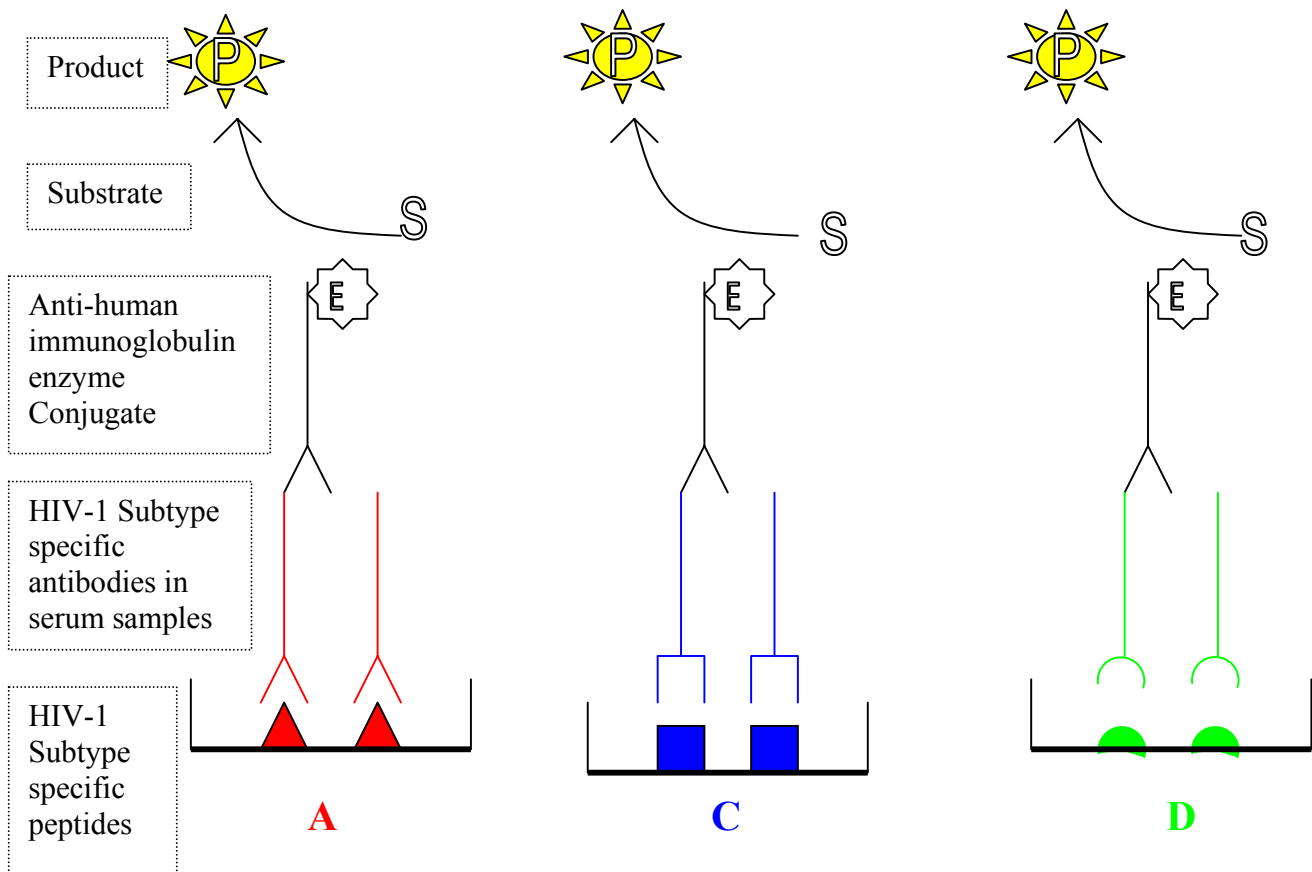

Figure 6. Peptide-binding enzyme immunoassay

In subtyping as reported by Kaleebu et al. (2), the use of the V3-peptide antigen limiting dilution assay and the gp41 PEIA followed by HMA and then DNA sequencing for untypable samples by PEIA and HMA gave an accuracy of 95% in Uganda were subtypes A and D are predominant. The combination of V3 and gp41 PEIAs correctly

typed 78% of the samples. This is an acceptable level of accuracy for a large-scale epidemiological study.

The total cost for consumables was reduced when subtyping was based on an algorithm in which all the samples were screened by PEIA followed by HMA and finally DNA sequencing on untypable samples. The UNAIDS Network for HIV Isolation and Characterization has reported that subtype A and D are difficult to differentiate by V3 PEIA alone (35) (37). In addition, HIV-1 subtypes A and C have numerous common amino acids in V3 region and are also difficult or impossible to distinguish by V3 PEIA alone.

Rationale for using PEIA

HIV-1 subtyping can be done by molecular biological or serological techniques. PEIA is a serological method. Many groups have reported a good correlation between the results of HIV-1 subtyping using serological and molecular techniques (2) (35-38). Synthetic peptides representing dominant antigenic epitopes in the V3-loop of the envelope glycoproteins gp120 and gp41 are commonly used in PEIA. The amino acid sequences of the peptides are based on the HIV-1 subtype consensus sequences for the V3-loop and gp41. Synthetic peptides are used as antigens in serotyping of HIV-1. Studies using PEIA in Thailand and Uganda correctly predicted 80% to 95% of HIV-1 genotypes (36) (2). This is sufficient for population-based epidemiological purposes. Genetic subtyping using differential PCR (36), DNA sequencing and HMA provides a more reliable and comprehensive approach to HIV-1 subtyping. These methods are costly, time and labour intensive, technically difficult and require sophisticated equipment not available in field

settings. HMA needs a number of reference standards for each subtype used in the assay. This makes genetic subtyping unsuitable for population-based studies with large numbers of samples. Genetic subtyping is too expensive to be performed in developing countries such as Tanzania.

Serological subtyping can supplement genetic subtyping, enable the use of banked sera and allow large numbers of samples to be studied. The method is simple, economical, less technically rigorous, there is no need for sophisticated equipment, it is easy to obtain small volumes of serum for analysis and it can be done in the field settings where large-scale vaccine trials are likely to occur. Therefore, we decided to use this methodology for subtyping HIV-1 in northern Tanzania where previous studies have shown subtypes A, C and D to be predominant.

Aim of the study

Tanzania is one of the SSA countries that have been most affected by the HIV-1 epidemic. Intervention measures have reduced HIV-1 infection rates in some areas in Tanzania. A decline in the prevalence of HIV-1 from 13.7% in 1996 to 7% in 1999 among pregnant women attending antenatal clinic in Bukoba urban in Kagera region was reported (8). An effective vaccine against HIV infection may provide one way to prevent the fast increase of the HIV/AIDS epidemic. The genetic variability of HIV is one of the major obstacles for the development of effective HIV vaccines.

In July 2000, during the AIDS Conference in Durban, South Africa, it was announced that the first HIV-1 vaccine candidates designed for Africa would be entering Phase I clinical trials in Kenya and South Africa. In a collaboration between British and Kenyan

scientists, a vaccine based on HIV-1 subtype A has being developed. In South Africa, a candidate vaccine designed using an attenuated form of Venezuelan equine encephalitis virus with genes from HIV-1 subtype C isolates will be entering clinical trials in the near future. The International AIDS Vaccine Initiative (IAVI) together with U.S. National Institute of Allergy and Infectious Diseases and the South African AIDS Vaccine Initiative are funding the development of these vaccines (39).

The northern part of Tanzania is famous for its national parks and tourist industry. In addition, the famous trunk road from Kenya to southern Africa passes through the region. For Tanzania, being geographically situated in the middle of the two vaccine trial countries, it is important to know which HIV-1 subtypes are circulating in the event vaccine studies will be conducted in this region. The efficacy of these candidate vaccines may be strain- or subtype-specific. It is therefore important to know the distribution of the HIV-1 subtypes in order to determine the relevance of proposed vaccine candidates and to add valuable information regarding the composition of future vaccines suitable for Tanzania.

Research hypothesis

In northern Tanzania, the epidemic has been growing since 1983 and there is a possibility that the patterns of circulating HIV-1 subtypes have changed over time.

Main objective of the study

The objective of the present study was to determine the evolution of HIV-1 subtypes in northern Tanzania for the period from 1985 to 2001.

Specific objectives

- To establish the peptide ELISA at Kilimanjaro Christian Medical Centre (KCMC).
- To evaluate changes in the pattern of HIV-1 subtypes in northern Tanzania from 1985 to 2001.
- To determine the present circulating HIV-1 subtypes in northern Tanzania.
- To generate information useful for future HIV-1 vaccine studies.

Materials and methods

Study site

This study was conducted at the Kilimanjaro Christian Medical Centre (KCMC) in Moshi, Tanzania, and was designed to study changes in the circulating subtypes, genetic diversity and distribution pattern of HIV-1 subtypes in northern Tanzania for the period from 1985 to 2001. KCMC is a referral and university hospital for the northern zone of Tanzania, which covers Tanga, Kilimanjaro, Arusha, Singida and Dodoma administrative regions. The five regions have an estimated population of 7.2 million with Tanga, Kilimanjaro, Arusha, Singida and Dodoma having populations of 1.7, 1.9, 2.0, 1.0 and 1.6 million, respectively (Planning Commission, 1999). These regions border with Kenya in the north, the Indian Ocean on the east, Mara, Shinyanga and Tabora regions on the west and Pwani, Morogoro and Iringa regions in the south (figure 7).



Fig. 6 Map of United Republic of Tanzania.

Source: <http://www.lib.utexas.edu/maps/africa/tanzania.gif>

● - Study site.

Study design

A retrospective study was conducted on HIV-1 positive frozen serum samples from patients who attended the outpatient clinics and/or were admitted to KCMC in the period from 1985 to 2001.

Peptides

A panel of gp120 V3 synthetic peptides derived from a consensus of V3 sequences representing HIV-1 subtypes A to E was kindly provided by the Centralized Facility for AIDS Reagents, UK Medical Research Council. The purity of the peptides was >80% and the amino acid sequences are shown in Table 2.

Table 2. Amino acid sequences of gp120 V3 peptides

HIV-1 V3 Subtype	Sequence
Peptide A consensus	K S V H I G P G Q A F Y A T
Peptide B consensus	K S I H I G P G R A F Y T T
Peptide C consensus	K S I R I G P G Q T F Y A T
Peptide D consensus	R Q R T H I G P G Q A L Y T T
Peptide E consensus	R T S I T I G P G Q V F Y R T

A – E consensus gp120 V3 peptides

In addition, gp41 peptides representing HIV-1 subtypes A and D generously donated by Dr. Chou Pau of the Centers for Disease Control in Atlanta, Georgia, USA were included in the study. These peptides were derived from the immunodominant region (IDR) of gp41 from HIV-1 LAI, a French subtype B isolate (40) and HIV-1 ELI, a Zairean subtype D isolate. Most European and African sera from HIV-1 infected individuals recognize the IDR-A peptide derived from the HIV-1 LAI isolate while the IDR-D peptide is characteristic of HIV-1 subtype D (<http://www.nibsc.ac.uk/catalog/aids-reagent>). The amino acid sequences of IDR-A and IDR-D are shown in Table 3.

Table 3. Amino acid sequence of gp41 peptides used

HIV-1 gp 41 subtype	Sequence
IDR-A	QQLLGIWGC SGKLICTT
IDR-D	QQLLGIWGC SGKHICTT

IDR = *Immunodominant region of gp41*

Serum specimens

Two hundred twenty six HIV-1 positive serum samples were retrieved from the -20°C freezers at the Research Laboratory at KCMC. The serum samples were collected from patients who attended KCMC and tested positive for HIV-1 antibodies. Information on the patients' sex, age, region of living and marital status was obtained for some of the patients. Patient's hospital number was used to countercheck repetitions of analyzing samples collected from the same patient at different times. The serum samples were tested by various screening techniques and confirmed by Western blot (Wb) with assays

provided by various manufactures during the period from 1985 to 2001. The sera were immediately frozen at -20°C after Wb confirmation and never subjected to thawing and freezing.

Serum sample selection

HIV-1 positive serum samples were sorted into four groups representing time of collection. The four groups included all samples collected in 1985/86, 1990/91, 1995/96 and 2000/01. Serum samples were thawed and an aliquot of 100 µL was used in the analysis. The groups comprised 25, 74, 29 and 98 samples for the groups representing 1985/86, 1990/91, 1995/96 and 2000/01, respectively.

Serum sample controls

Seronegative control samples that were collected during the same period were included in each run to determine cut-off (CO) and to control the sensitivity and specificity of the PEIA. A panel of seropositive control serum samples from previously genetically characterized HIV-1 subtypes kindly donated by the Uganda Virus Research Institute in Entebbe was included in each test run to ensure the validity of our results.

Sample analysis

All 226 serum samples were subjected to indirect PEIA against gp120 V3 peptides A to E and gp41 A and D peptides. The sera that showed high antibody binding with gp120 V3 D peptide and reactive to gp41 D peptide were confirmed as subtype D. The rest were

subjected to the antigen limiting dilution assay using gp120 V3 peptides. The peptide that showed high antibody binding at the highest antigen dilution determined the subtype for the serum sample.

V3 PEIA

Reagents were prepared according to the protocol given in the appendix. Serum samples were tested for antibody binding to V3 by an indirect PEIA as previously described (35). The supplied freeze-dried peptides were reconstituted using double distilled water to a concentration of 1000 µg/mL. The peptide solution was kept frozen at -20°C in aliquots of 50 µL in glass vials with teflon coated tops and thawed only once before use. The V3 peptides were coated directly on ELISA microtitre plates (Nunc immunosorb, 439454 F96 Cert. Maxisorb) with 100 µL in each well at a concentration of 5 µg/mL in 20 mM carbonate buffer (pH 9.6) for 48 hours at room temperature. The plates were washed twice with wash buffer, blocked with blocking buffer and then washed six times using wash buffer. Coated plates were kept at 4°C until use. Serum samples were diluted to 1:100 in serum diluent buffer and 100 µL of the diluted samples were incubated with the immobilized peptides at 37°C for 90 minutes. The plates were washed six times with wash buffer and then incubated with rabbit anti-human immunoglobulin peroxidase conjugate (Sigma-Aldrich, Saint Louis, Missouri, USA) at a dilution of 1:6,000 for 1 hour at 37°C to react with the bound antibody. The excess conjugate was removed by washing six times using wash buffer. The colour was developed by incubating the plates with *ortho*-phenylenediamine dihydrochloride (OPD) substrate (Sigma-Aldrich, Saint Louis, Missouri, USA) for 20 minutes at room temperature in the dark. The colour

development was stopped by addition of 1 M sulphuric acid and the optical densities (OD) were measured spectrophotometrically at 492 nm. Twelve HIV-1 negative sera were included for each run of the peptide on each ELISA plate. The OD of the negative controls was used for the calculation of the cut-off value. The cut-off value was determined by calculating [(mean OD of the negative samples + 3SD) X 2]. Furthermore, the ratio of the antibody bound to the peptide to the cut-off value was calculated (OD/CO). Serum samples yielding a ratio greater than one were subjected to antigen limiting dilution assay.

V3 peptide antigen limiting dilution assay

The V3 peptide was coated on the same type of microtitre ELISA as previously described plates at a concentration of 1, 0.1 and 0.01 µg/mL in 20 mM carbonate buffer (pH 9.6). Each well was coated with 100 µL of each peptide dilution. The sera were used at a single dilution of 1:100 and 100 µL was added to each well. The rest of the PEIA was performed exactly as the indirect PEIA described above. Antibody-binding ratio (OD/CO) was calculated for each peptide at each dilution and the highest antibody-binding ratio at the highest antigen dilution indicated the subtype of the particular serum specimen.

gp41 PEIA

Each individual peptide was dissolved in dimethyl sulfoxide (DMSO) at 5 mg/mL and aliquoted into 50 µL volumes in glass vials with teflon coated cap liners and stored at

-20°C until use. The microtitre ELISA plates were coated with peptide at a concentration of 2.5 µg/mL in freshly prepared cold 0.1M carbonate-bicarbonate buffer (pH 9.6). In each well 100 µL of the peptide was added and incubated overnight at 4°C. The plates were washed with wash buffer 2 times, air-dried at 37°C for 15 minutes and stored at -20°C until use. The PEIA was performed exactly as in indirect PEIA except that a 1:200 serum dilution was used.

Results

Of the 226 serum samples that were analyzed, 196 (87%) samples could be subtyped and 30 (13%) could not be subtyped using PEIA and the antigen limiting dilution assay. One hundred and eighteen (52%) samples were from males, 98 (43%) were from females and for 10 (5%) the gender was not available. The minimum age was 1 year and maximum age was 66 years with a mean age of 34 years. Ages were grouped into 15-year intervals. Children under 15 years were 15 (7%), 16 to 30 years were 64 (28%), 31 to 45 years were 93 (41%), 46 to 66 years were 32 (14%) and 22 (10%) were of unknown age. Most of the patients, 105 (47%), were inhabitants of the Kilimanjaro region followed by neighbouring regions of Arusha 24 (11%), Tanga 7 (3%) and Dar es Salaam 6 (3%). Two patients (1%) came from Mwanza region and the remaining 2% came from Pwani, Mara, Mbeya, Rukwa and Kagera regions with one patient each. The regions from which 77 (34%) patients came from were not known. HIV-1 subtypes A, C and D were the subtypes that were found to circulate in northern Tanzania.

During the initial screening by the indirect PEIA there was an equivocal antibody binding by some serum samples to some V3 peptides. This cross-reactivity was shown by subtype

A cross-reacting with C, D and E peptides while subtype C cross-reacted with subtypes E, A and D peptides. Subtype D cross-reacted with A, B and C peptides. All the serum samples were subjected to gp41 A and D peptides and 68 samples did not react with either of the two peptides. Out of 62 samples that were typed as subtype D, 50 serum samples reacted with gp41 D peptides. The 12 samples that did not react with the gp41 D peptide had a high antibody-binding ratio to V3 peptide D in the indirect PEIA despite 8 (13%) and 4 (6%) samples showing cross-reaction with peptide B and C respectively. Of the 62 typed D sera, 48 (77%) were in agreement with both V3 indirect PEIA and gp41 D. Of the remaining 2 (4%) samples, one showed to cross-reacted with A peptide and the other was non-reactive by indirect PEIA. One hundred and eight samples reacted with the gp41 A peptide and 54 of these samples had a high antibody-binding ratio to V3 peptide C by both antigen limiting dilution assay and indirect PEIA. Hence, they were typed as HIV-1 subtype C. The remaining 54 samples were typed as HIV-1 subtype A. The gp41 peptide non-reacting 68 samples were subjected to antigen limiting dilution assay and indirect PEIA whereby 30 samples were untypable. The 38 serum samples that were typed, 12 samples were typed as HIV-1 subtype D, 11 samples as HIV-1 subtype A and 15 samples as HIV-1 subtype C. Distribution of these subtypes with time is summarized in Table 4.

Table 4. Distribution of HIV-1 subtypes among serum samples stored at KCMC from 1985 to 2001.

SUBTYPE	PERIOD IN YEARS				TOTAL
	1985/86	1990/91	1995/96	2000/01	
	n (%)*	n (%)*	n (%)*	n (%)*	
A	11 (52)	24 (35)	3 (13)	27 (32)	65
C	0 (0)	14 (20)	13 (57)	42 (51)	69
D	10 (48)	31 (45)	7 (30)	14 (17)	62
NT	4 (16)	5 (7)	6 (21)	15 (15)	30
TOTAL	25	74	29	98	226

* n (%) = *number (percentage)*

NT = non-typable

The highest prevalence of HIV infection occurred in females of age group of 16 to 30 years and males of age group of 31 to 45. The predominance of HIV-1 subtype C was equivalent among women in age groups 16 to 30 years and 31 to 45 years. Summary of the distribution of subtypes among the age groups in both sexes is shown in Table 5.

Table 5: Distribution of subtypes among age groups of females and males in samples collected from 1985 to 2001 at KCMC.

SUBTYPE	AGE GROUP	SEX		
		Unknown	F n (%)*	M n (%)*
A	0 –15yrs			15 (14)
	16 –30yrs		14 (52)	5 (14)
	31 – 45yrs		4 (15)	17 (46)
	46 – 66yrs		5 (18)	8 (21)
	Unknown		4 (15)	2 (5)
Total		1	27	37
C	0 –15yrs		4 (11)	3 (11)
	16 –30yrs		13 (34)	2 (7)
	31 – 45yrs		14 (37)	14 (50)
	46 – 66yrs		2 (5)	6 (21)
	Unknown		5 (13)	3 (11)
		3	38	28
D	0 –15yrs		1 (4)	
	16 – 30yrs		14 (51)	7 (21)
	31 – 45yrs		10 (37)	20 (60)
	46 – 66yrs		1 (4)	5 (15)
	Unknown		1 (4)	1 (3)
Total		2	27	33
TOTAL		6	92	98 196

F –female, M – male,

* n (%) – number (percentage). Bold indicates the age groups with highest prevalence of each respective subtype.

The 196 serum samples that were successfully subtyped were divided into two groups. The first group was the samples collected in period from 1985 to 1991 and the second group was the samples collected in 1995 to 2001.

During 1985 to 1991 period subtypes A and D were more predominant than subtype C in males while subtype D was more predominant in females. During the period 1995 to 2001 subtype A remained constant in both males and female while subtype C increased and subtype D decreased. Table 6 summarizes of the distribution of subtypes among females and males in the 1985 to 1991 and 1995 to 2001 time periods.

Table 6: Distribution of HIV-1 subtypes in females and males during 1985 to 1991 and 1995 to 2001 from samples stored at KCMC.

PERIOD	SEX	SUBTYPE (n)*			TOTAL
		A	C	D	
1985 –1991	F	12	7	18	37
	M	22	6	23	51
	Unknown	1	1		2
Total		35	14	41	90
1995 – 2001	F	15	31	9	55
	M	15	22	10	47
	Unknown		2	2	4
Total		30	55	21	106

F – female and M – male,

* (n) – number

Most prevalent subtypes are in bold.

Discussion and conclusion

Epidemiological studies on the genetic diversity of HIV-1, particularly the current circulating subtypes in different parts of the world, yield information of importance for vaccine development. Establishing cost-effective methodologies in countries with limited resources is especially important in the HIV-1 endemic areas where HIV-1 diversity is greatest and HIV-1 vaccine studies are urgently needed. Different HIV-1 subtypes occur worldwide with different patterns of geographical distribution. Serological methods using synthetic peptides from consensus sequences of HIV-1 genomes especially from the gp120 V3 loop and gp41 have been used for subtyping HIV-1 (2)(35)(37). These methods are of great importance in monitoring the spread of HIV-1 subtypes. They are inexpensive, do not need highly trained personnel and enable large-scale screening for epidemiological studies. In contrast to the previous serological studies on HIV-1 subtyping, our study was done in an epidemic area where multiple subtypes are co-circulating with a recent increase in the prevalence of subtype C.

Our study aimed at presenting the trend in incidences of HIV-1 subtypes starting from the early years of the epidemic using an inexpensive method that can be applied in a country with limited resources. Furthermore, we aimed at presenting the current circulating subtypes in Tanzania, a country that has one of the high prevalence of HIV-1 infections within the SSA. The samples analyzed in this study included serum specimens that were drawn from patients who attended KCMC in four periods of 1985/86, 1990/91, 1995/96 and 2000/01 and were confirmed to be HIV-1 seropositive. The results show that HIV-1 subtypes A and D were the first to circulate and in equal proportions during the start of the epidemic. Our study has shown that HIV-1 subtypes A, C and D are currently co-

circulating in northern Tanzania. HIV-1 subtype C was first identified in the 1990/91 group of serum samples. This suggests that subtype C was probably introduced into the population during late 1980s. Our study also shows that subtype C is increasing in prevalence as the time goes on. Currently subtype C is circulating at a higher proportion followed by subtype A that has remained constant while subtype D is decreasing over time (Table 1). In other parts of Tanzania such as southwest in the Mbeya region, subtype C was reported to circulate at a higher proportion and has remained stable since 1989 (33). In Uganda, where the epidemic started more or less at the same time as Tanzania, a stable predominance of subtypes A and D with only limited distribution of subtype C has been reported (41). This is also the situation in Kenya where subtypes A and D predominate with limited proportions of subtype C and G (42). This suggests that subtype C may have spread through southwest Tanzania to the northern region, possibly through the traders between bordering Zambia and Malawi where subtype C predominates. The increase in subtype C and decrease in subtype D HIV-1 in Tanzania raises research questions that need to be addressed.

The distribution of HIV-1 subtypes did not differ significantly between the sexes within a given time frame (Table 6). From the serum samples included in our study, it is not possible to determine whether a specific subtype was most prevalent within a given age group. The serum samples included in our study represent all serum samples stored at the Research Laboratory at KCMC for each given time period. Therefore, we can conclude that HIV infection is most prevalent among women aged 16 to 30 years and among men aged 31 to 45 years in this study (Table 5). It is well known that HIV infection is most prevalent among sexually active persons and that men with HIV infection are on average

older than women in SSA. However, it is of interest to note that the prevalence of HIV-1 subtype C is equivalent among women in age groups 16 to 30 and 31 to 45 years. This may reflect the recent increase of HIV-1 subtype C infections as previously discussed or a possibility of slow disease progression among persons with HIV-1 subtype C infections. In order to make a statement regarding the distribution of HIV-1 subtypes between different age groups, we would have to include equal numbers of samples from each age group. We successfully established PEIA at KCMC and used this assay for our sample analysis. Our results are in agreement with the previous studies done in Tanzania. Studies conducted in Dar-es-Salaam have shown the same distribution of HIV-1 subtypes during of the 1990s (25)(27)(29-32). However, a study done in Kilimanjaro did not indicate the same distribution and showed the presence of subtype B-like viruses(28). Our study used a different methodology with a sample size five times greater than that used in the previous Kilimanjaro study. We could not detect subtype B. These data warrant further studies in this population as subtype B has not been documented elsewhere in Tanzania to date.

Serotyping using PEIA in combination with the antigen limiting dilution assay using envelope peptides provides a good tool for determining the prevalence of different HIV-1 subtypes. The peptides that were used in our study were identical to those used by Kaleebu in Uganda and Cheingsong-Popov on samples from Uganda and Rwanda (2)(35). Tanzanian sera showed cross-reactions especially between A, C and E, and also between D and B in accordance to previous reports (2)(35). Most of the serum samples that showed a high antibody-binding ratio among the cross-reacting sera on indirect PEIA also showed high antibody-binding on the antigen limiting dilution assay on low antigen

concentrations. Our approach of combining the V3 and gp41 PEIAs and the antigen limiting dilution assay enabled us to determine the subtypes co-circulating in northern Tanzania. Further studies are needed especially to determine a suitable consensus peptide for the Tanzanian HIV-1 subtype A.

The antigen limiting dilution assay in combination with the gp41 PEIA discriminates between cross-reacting subtypes. Subtype C could be distinguished from cross-reacting subtypes such as A by the use of the antigen limiting dilution assay in contrast to previous reports (35)(37). As the samples included in our study were not genetically characterized, there is a need to evaluate the antigen limiting dilution assay for discriminating genetically typed subtypes A and C. Such studies are imperative for the use of the antigen limiting dilution assay in Tanzania where HIV-1 subtypes A and C are co-circulating. In addition, we could not detect the CRF reported in previous studies done in Tanzania (Table 1). This is one of the limitations of PEIA in HIV-1 subtyping.

In our study sample we could not subtype 30 (13%) sera by a combination of PEIA and the antigen limiting dilution assay. It is conceivable that some serum samples had antibodies concentration below the level of detection by these assays. This was also demonstrated in Uganda (2) where 18% were untypable. These data warrant further studies in which samples are subjected to methods such as HMA and DNA sequencing in addition to PEIA. While inexpensive methods can be used to determine the HIV-1 subtypes in countries with limited resources, there is a need for genetic methods such as HMA and DNA sequencing to describe the genetic diversity in detail. Furthermore, international collaboration is needed in which groups with adequate resources, both

financial and technical, can perform analyses that are not possible in countries where laboratories have limited facilities and funding.

The peptide-binding enzyme immunoassay used in this study is a great aid in determining the prevalence of circulating HIV-1 subtypes within a given region. In addition, this method is suitable for use in developing countries at referral laboratories. It is important to know what subtypes are circulating in any given region with respect to the administration of an effective vaccine against HIV-1. The data generated in this study may be helpful should Tanzania become involved in vaccine trials in the near future.

Appendix

Preparation of buffers:

1. 20 mM carbonate buffer, pH 9.6

Anhydrous Na_2CO_3 M.W = 105.99

Dissolve 2.12 gm in about 800 ml of distilled water. Initial pH is about 11, adjust to 9.6 by drop wise addition of concentrated hydrochloric acid and make to one litre with distilled water.

2. 0.1 M Phosphate citric acid buffer, pH 5.0.

Dissolve 6.66 gm of citric acid and 9.46 gm of disodium monohydrogen phosphate in about 800 ml of distilled water. Adjust pH and make up to one litre with distilled water.

3. 10X - Phosphate buffered saline (PBS), pH 7.4

Dissolve 80 gm of NaCl, 2 gm of KCl, 11.5 gm of disodium monohydrogen phosphate and 2 gm of potassium dihydrogen phosphate in about 900 mL of distilled water. Adjust pH and make to one litre with distilled water.

4. PBS for use.

Dilute the 10X PBS to 1 in 10 with distilled water. Check pH.

5. Washing buffer

Add 500 μL of Tween 20 in one litre of PBS for use.

6. Blocking buffer (100 mL preparation)

Dissolve 5 gm of powdered skimmed milk in 90 mL of PBS for use and add 10 mL of heat-inactivated newborn calf serum.

7. Serum diluting buffer (100 mL preparation)

Add 100 μL of Tween 20 into 99.9 mL of blocking buffer.

8. Stop solution

1 M sulphuric acid.

References

1. UNAIDS/WHO. Global HIV/AIDS update. December 2001.
2. Kaleebu P, Yirrell D, French N, Lyagoba F, Rutebemberwa A, Cheingsong-Popov R, et al. *An improved algorithm for determining HIV type 1 subtypes in a primary laboratory in Uganda.* AIDS Res Hum Retroviruses 2000;16(7):621-5.
3. Harris C, Small CB, Klein RS, Friedland GH, Moll B, Emeson EE, et al. *Immunodeficiency in female sexual partners of men with the acquired immunodeficiency syndrome.* N Engl J Med 1983;308(20):1181-4.
4. Mansur. *An Outlook of Acquired Pneumocyst carinii pneumonia.* N Eng J Med 1981(305):1431.
5. Colebunders R, Kapita B, Nekwei W, Bahwe Y, Lebughe I, Oxtoby M, et al. *Breastfeeding and transmission of HIV.* Lancet 1988;2(8626-8627):1487.
6. Stewart GJ, Tyler JP, Cunningham AL, Barr JA, Driscoll GL, Gold J, et al. *Transmission of human T-cell lymphotropic virus type III (HTLV-III) by artificial insemination by donor.* Lancet 1985;2(8455):581-5.
7. Mhalu F, Bredberg-Raden U, Mbena E, Pallangyo K, Kiango J, Mbise R, et al. *Prevalence of HIV infection in healthy subjects and groups of patients in Tanzania.* AIDS 1987;1(4):217-21.
8. NACP-MOH Tanzania. National AIDS Control Programme HIV/AIDS/STD Surveillance; 1999 September 2000. Report No.: 14.
9. NACP-MOH Tanzania. National AIDS Control Programme HIV/AIDS/STD Surveillance; 2000. Report No.: 15.

9. UNAIDS/WHO. *AIDS Epidemiological Fact Sheet on HIV/AIDS and Sexually Transmitted Infections, 2000 Update*; 2000 June 2000.
10. Chiu IM, Yaniv A, Dahlberg JE, Gazit A, Skuntz SF, Tronick SR, et al. *Nucleotide sequence evidence for relationship of AIDS retrovirus to lentiviruses*. *Nature* 1985;317(6035):366-8.
11. Jawetz L. *Medical Microbiology & Immunology: Examination & Board Review*. Sixth ed: Lange/McGraw-Hill; 2000.
12. Saha K. *Isolation of primary HIV-1 that target CD+8 T lymphocytes using CD8 as a receptor*. *Nat Med* 2001;7(1):65-72.
13. Saha K, Zhang J, Zerhouni B. *Evidence of productively infected CD8+ T cells in patients with AIDS: Implications for HIV-1 pathogenesis*. *J Acquir Immune Defic Syndr* 2001;26(3):199-207.
15. Vaishnav YN, Wong-Staal F. *The biochemistry of AIDS*. *Annu Rev Biochem* 1991;60:577-630.
16. Preston. *Fidelity of HIV-1 reverse transcriptase*. *Science* 1988;242 (4882): 1168 - 71.
17. Bebenek K, Abbotts J, Roberts JD, Wilson SH, Kunkel TA. *Specificity and mechanism of error-prone replication by human immunodeficiency virus-1 reverse transcriptase*. *J Biol Chem* 1989;264(28):16948-56.
18. Delwart EL, Shpaer EG, Louwagie J, McCutchan FE, Grez M, Rubsamen-Waigmann H, et al. *Genetic relationships determined by a DNA heteroduplex mobility assay: analysis of HIV-1 env genes*. *Science* 1993;262(5137):1257-61.

19. <http://hiv-web.lanl.gov/content/hiv-db/HelpDocs/subtypes-more.html>.
20. Robertson DL, Anderson JP, Bradac JA, Carr JK, Foley B, Funkhouser RK, et al. *HIV-1 nomenclature proposal*. Science 2000;288(5463):55-6.
21. Triques K, Bourgeois A, Vidal N, Mpoudi-Ngole E, Mulanga-Kabeya C, Nzilambi N, et al. *Near-full-length genome sequencing of divergent African HIV type 1 subtype F viruses leads to the identification of a new HIV type 1 subtype designated K*. AIDS Res Hum Retroviruses 2000;16(2):139-51.
22. McCutchan FE. *Understanding the genetic diversity of HIV-1*. AIDS 2000;14 Suppl 3:S31-44.
23. Wolf D. *Syncytium-inducing and non-inducing capacity of human immunodeficiency virus type 1 subtypes other than B phenotypic and genotypic characteristics*. WHO Network for HIV Isolation and Characterization. AIDS Res Hum Retroviruses 1994;10(11):1387-400.
24. Holm-Hansen C, Baan E, Asjo B, Pascu FR, Goudsmit J, De Jong JJ. *Determinants for the syncytium-inducing phenotype of HIV-1 subtype F isolates are located in the V3 region*. AIDS Res Hum Retroviruses 2000;16(9):867-70.
25. Blackard JT, Renjifo B, Chaplin B, Msamanga G, Fawzi W, Essex M. *Diversity of the HIV-1 long terminal repeat following mother-to-child transmission*. Virology 2000;274(2):402-11.
26. Hoelscher M, Hanker S, Barin F, Cheingsong-Popov R, Dietrich U, Jordan-Harder B, et al. *HIV type 1 V3 serotyping of Tanzanian samples: probable reasons for mismatching with genetic subtyping*. AIDS Res Hum Retroviruses 1998;14(2):139-49.

27. Holm-Hansen C, Stern B, Rustad S, Shao J, Asjo B. *V3 sequence analysis and biological characterization of HIV-1 isolates from asymptomatic and early symptomatic Tanzanian individuals*. APMIS 2000;108(9):608-16.
28. Kiwelu IE, Nakkestad HL, Shao J, Sommerfelt MA. *Evidence of subtype B-like sequences in the V3 loop region of human immunodeficiency virus type 1 in Kilimanjaro, Tanzania*. AIDS Res Hum Retroviruses 2000;16(12):1191-5.
29. Renjifo B, Chaplin B, Mwakagile D, Shah P, Vannberg F, Msamanga G, et al. *Epidemic expansion of HIV type 1 subtype C and recombinant genotypes in Tanzania*. AIDS Res Hum Retroviruses 1998;14(7):635-8.
30. Renjifo B, Gilbert P, Chaplin B, Vannberg F, Mwakagile D, Msamanga G, et al. *Emerging recombinant human immunodeficiency viruses: uneven representation of the envelope V3 region*. AIDS 1999;13(13):1613-21.
31. Renjifo B, Fawzi W, Mwakagile D, Hunter D, Msamanga G, Spiegelman D, et al. *Differences in perinatal transmission among human immunodeficiency virus type 1 genotypes*. J Hum Virol 2001;4(1):16-25.
32. Lyamuya E, Olausson-Hansson E, Albert J, Mhalu F, Biberfeld G. *Evaluation of a prototype Amplicor PCR assay for detection of human immunodeficiency virus type 1 DNA in blood samples from Tanzanian adults infected with HIV-1 subtypes A, C and D*. J Clin Virol 2000;17(1):57-63.
33. Hoelscher M, Kim B, Maboko L, Mhalu F, von Sonnenburg F, Birx DL, et al. *High proportion of unrelated HIV-1 intersubtype recombinants in the Mbeya region of southwest Tanzania*. AIDS 2001;15(12):1461-70.

34. Pau CP, Lee-Thomas S, Auwanit W, George JR, Ou CY, Parekh BS, et al. *Highly specific V3 peptide enzyme immunoassay for serotyping HIV-1 specimens from Thailand.* AIDS 1993;7(3):337-40.
35. Cheingsong-Popov R, Lister S, Callow D, Kaleebu P, Beddows S, Weber J. *Serotyping HIV type 1 by antibody binding to the V3 loop: relationship to viral genotype.* WHO Network for HIV Isolation and Characterization. AIDS Res Hum Retroviruses 1994;10(11):1379-86.
36. Gaywee J, Artenstein AW, VanCott TC, Trichavaroj R, Sukchamnong A, Amlee P, et al. *Correlation of genetic and serologic approaches to HIV-1 subtyping in Thailand.* J Acquir Immune Defic Syndr Hum Retrovirol 1996;13(4):392-6.
37. Cheingsong-Popov R, Osmanov S, Pau CP, Schochetman G, Barin F, Holmes H, et al. *Serotyping of HIV type 1 infections: definition, relationship to viral genetic subtypes, and assay evaluation.* UNAIDS Network for HIV-1 Isolation and Characterization. AIDS Res Hum Retroviruses 1998;14(4):311-8.
38. Cheingsong-Popov R, Williamson C, Lister S, Morris L, van Harmelen J, Bredell H, et al. *Usefulness of HIV-1 V3 serotyping in studying the HIV-1 epidemic in South Africa.* AIDS 1998;12(8):949-50.
39. Connett H. *South African village prepares for first HIV vaccine trial.* Nat Med 2000;6(11):1199-200.
40. Wain-Hobson. *Nucleotide sequence of the AIDS virus, LAV.* Cell 1985;40 (1):9-17.
41. Hu DJ, Baggs J, Downing RG, Pieniazek D, Dorn J, Fridlund C, et al.
42. *Predominance of HIV-1 subtype A and D infections in Uganda.* Emerg Infect Dis 2000;6(6):609-15.

42. Neilson JR, John GC, Carr JK, Lewis P, Kreiss JK, Jackson S, et al. *Subtypes of human immunodeficiency virus type 1 and disease stage among women in Nairobi, Kenya.* J Virol 1999;73(5):4393-403.